

Balanced Output Stage

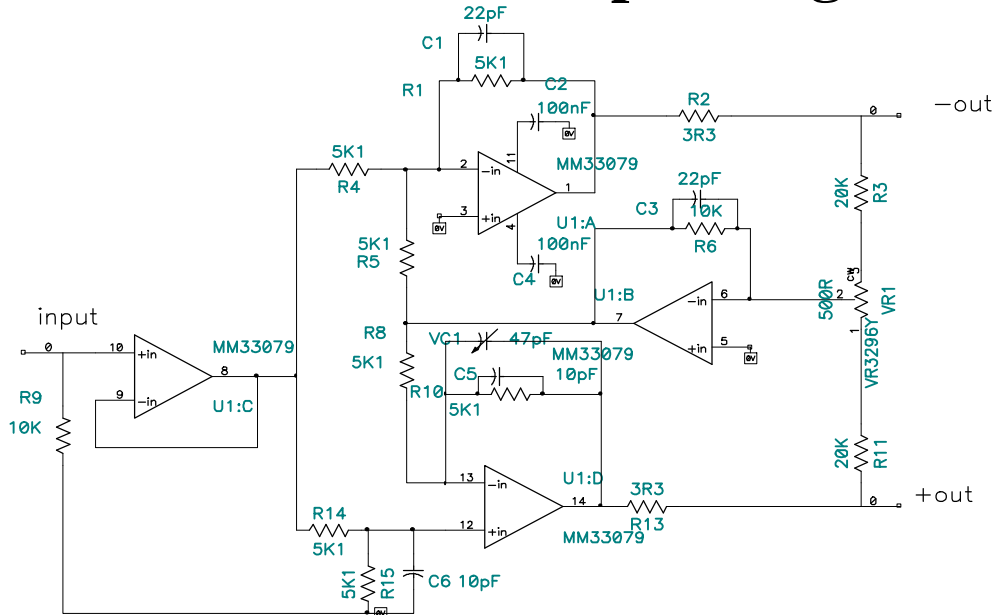

This is a very slightly modified version of Barry Porter's 1990 balanced output stage. C6 has been added, which gives a dramatic improvement in common mode output performance. It's all a balancing act between C1, C5 and C6, any one can be adjustable. It's value is quite critical and is dependant on what op amps are used.

This is a EWB simulation when C6 is in and out of tune, and omitted, with C5 adjusted for best performance

